

General-Purpose, Spring-Loaded Back-Pressure Regulators—BS(H)10 and BS(H)15 Series

Features

- Balanced poppet design
- Diaphragm sensing:
0 to 290 psig (0 to 20.0 bar)
- Piston sensing:
0 to 3625 psig (0 to 250 bar)
- High flow capacity

Options

- NACE MR0175/ISO 15156-compliant models
- Special cleaning to ASTM G93 Level C



Technical Data

Series	Maximum Inlet Pressure psig (bar)	Maximum Inlet Control Pressure psig (bar)	Sensing Type	Temperature Range °F (°C)	Flow Coefficient (C _v)	Seat Diameter in. (mm)	Connections			Weight (Without Flanges) lb (kg)
							Inlet and Outlet		Gauge	
							Size	Type		
BS(H)10	BS: 1015 (70.0)	BS: 290 (20.0)	Diaphragm: 0 to 290 psig (20.0 bar)	-4 to 176 (-20 to 80) See Pressure-Temperature Ratings , page 60.	3.84	0.53 (13.5)	1 in. DN25	NPT ISO/BSP parallel thread	1/4 in. NPT or ISO/BSP parallel ^①	16.7 (7.6)
BS(H)15	BSH: 3625 (250)	BSH: 3625 (250)	Piston: 0 to 3625 psig (0 to 250 bar)				7.3	0.75 (19.0)		1 1/2 in. DN40

① Regulators with NPT inlet / outlet connections have 1/4 in. NPT gauge connections.

Materials of Construction

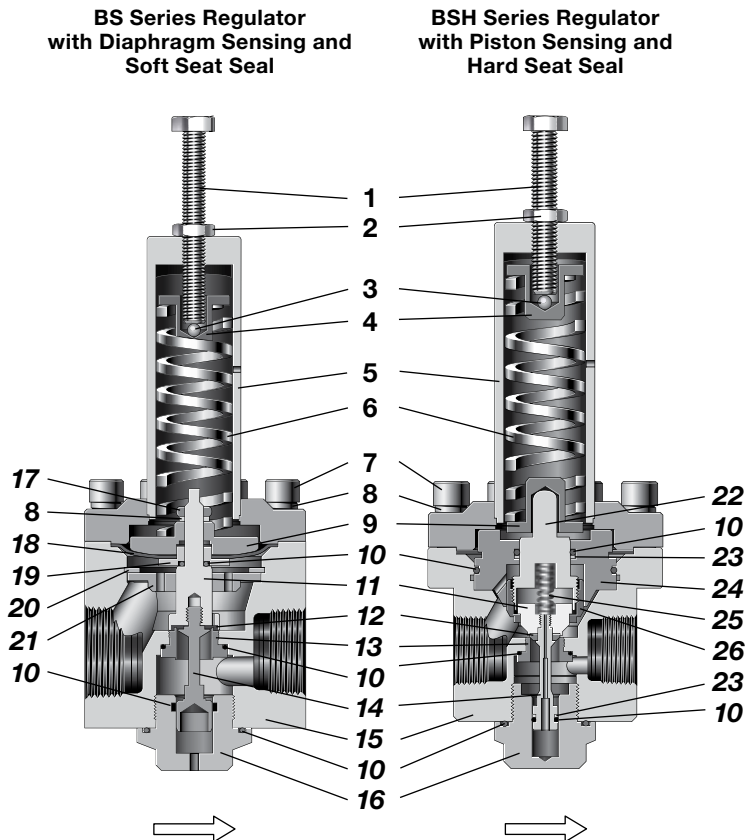

	Component	Material / Specification
Common Components	1 Adjusting screw	A2-70
	2 Set screw nut	A2
	3 Ball	420 SS (Hardened)
	4 Upper spring guide	316L SS / A479 or EN10088
	5 Spring housing assembly	
	6 Set spring	50CRV4
	7 Cap screw	A4-80
	8 Washer	A4
	9 Bottom spring guide	316L SS / A479 or EN10088
	10 O-ring	EPDM, FKM, or nitrile
	11 Poppet housing	316L SS / A479 or EN10088
12 Seat seal	BS	EPDM, FKM, or nitrile
	BSH	PCTFE or PEEK
13 Seat	316L SS / A479 or EN10088	
14 Poppet		
15 Body		
16 Body plug		
Diaphragm Only	17 Nut	A4
	18 Diaphragm	EPDM, FKM, or nitrile
	19 Clamp plate	316L SS / A479 or EN10088
	20 Retaining ring	1.4122 Steel
	21 Body plate	316L SS / A479 or EN10088
Piston Only	22 Piston	316L SS / A479 or EN10088
	23 Backup ring	PTFE
	24 Piston plate	316L SS / A479 or EN10088
	25 Overtravel spring	302 SS / A313
	26 Piston screw	316L SS / A479 or EN10088

Wetted components listed in *italics*.

Gauge plugs (not shown): 431 SS / A276.

Flow Data

For flow curve information, contact your authorized Swagelok representative.

Dimensions

Dimensions, in inches (millimeters), are for reference only and are subject to change.

Series	End Connection Size	Dimensions, in. (mm)					
		A	B	C	D	E	F
BS(H)10	1 in.	10.5 (266)	3.54 (90.0)	3.07 (78.0)	2.28 (58.0)	1.97 (50.0)	1.77 (45.0)
BS(H)15	1 1/2 in.	10.8 (275)	4.53 (115)	3.78 (96.0)	2.44 (62.0)	2.01 (51.0)	1.77 (45.0)

Gauge Connection

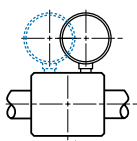

Only one gauge with a 50 mm (2 in.) or larger dial size fits directly into the body.

Configuration

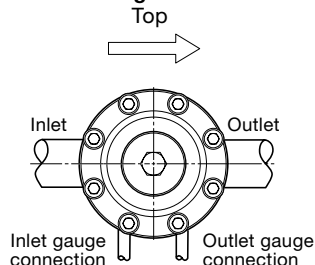

Shown with tubing for clarity; tubing not included.

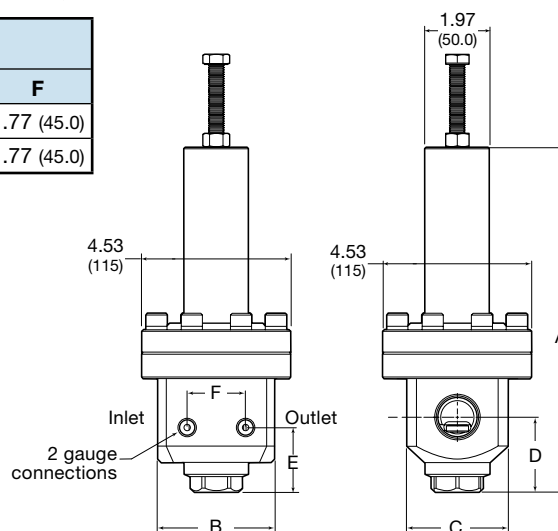

Ordering Information

Build a BS(H)10 and BS(H)15 series regulator ordering number by combining the designators in the sequence shown below.

1 2 3 4 5 6 7 8 9 10 11
BS FA 10 A 1 - 02 - 1 - V V V - N

1 Series

BS = 1015 psig (70.0 bar) maximum inlet pressure

BSH = 3625 psig (250 bar) maximum inlet pressure

2 Inlet / Outlet

B = Female ISO/BSP parallel thread

N = Female NPT

FA = ASME B16.5 flange

FD = EN 1092 (DIN) flange

3 Size

10 = 1 in. / DN25

15 = 1 1/2 in. / DN40

4 Pressure Class

Omit designator if flanges are not ordered.

A = ASME class 150

B = ASME class 300

C = ASME class 600

E = ASME class 1500

F = ASME class 2500

M = DN class PN16

N = DN class PN40

5 Flange Facing

Omit designator if flanges are not ordered.

1 = Raised face smooth

3 = RTJ

6 Body Material

02 = 316L SS

7 Pressure Control Range

Diaphragm sensing (BS series only)

1 = 0 to 43 psig (0 to 3.0 bar)

2 = 0 to 72 psig (0 to 5.0 bar)

3 = 0 to 145 psig (0 to 10.0 bar)

4 = 0 to 290 psig (0 to 20.0 bar)

Piston sensing (BSH series only)

5 = 0 to 580 psig (0 to 40.0 bar)

6 = 0 to 1450 psig (0 to 100 bar)

7 = 0 to 2610 psig (0 to 180 bar)

8 = 0 to 3625 psig (0 to 250 bar)

8 Seal Material

V = Fluorocarbon FKM

N = Nitrile

E = EPDM

9 Diaphragm / Piston O-Rings

V = Fluorocarbon FKM

N = Nitrile

E = EPDM

10 Seat Seal Material

BS series

V = Fluorocarbon FKM

N = Nitrile

E = EPDM

BSH series

K = PCTFE

P = PEEK

11 Options

N = NACE MR0175/ISO 15156

G93 = ASTM G93 Level C-cleaned