

## Steam-Heated Vaporizing, Diaphragm-Sensing Pressure-Reducing Regulator (KSV Series)

The KSV series is a steam-heated vaporizing regulator with a low internal volume. It can be used to vaporize liquid samples or to preheat gas samples to prevent them from condensing.

### Features

- Convolute, nonperforated diaphragm
- Metal-to-metal diaphragm seal
- Low internal volume

### Technical Data

#### Maximum Inlet Pressure

- 3600 psig (248 bar)

#### Outlet Pressure Ranges

- 0 to 10 psig (0.68 bar) through 0 to 500 psig (34.4 bar)

#### Flow Coefficient (C<sub>v</sub>)

- 0.06 or 0.20

### Supply-Pressure Effect

Flow Coefficient (C <sub>v</sub> )	Pressure Control Range	
	Up to 100 psig (6.8 bar)	250 psig (17.2 bar) and Higher
	Supply Pressure Effect, %	
0.06	1.0	1.5
0.20	1.5	2.4

### Maximum Steam Pressure and Temperature

- 650 psig (44.7 bar) and 500°F (260°C)

### Maximum Regulator Operating Temperature

- 392°F (200°C)

### Weight

- 3.3 lb (1.5 kg)

### Ports

- 1/8 in. female NPT inlet; 1/4 in. female NPT outlet(s)
- Steam tube 1/2 in. outside diameter, 0.049 in. wall



### Materials of Construction

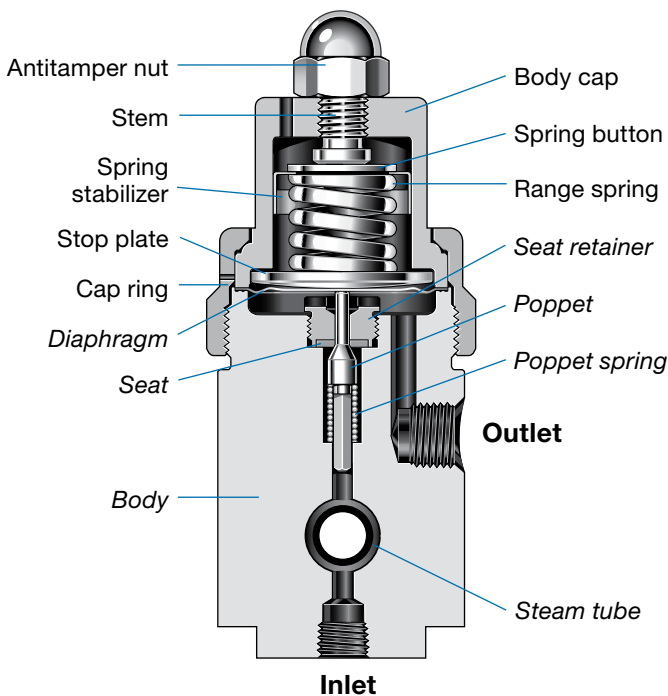

Component	Material
Antitamper nut, stem, cap ring, stop plate, body cap, panel nuts <sup>①</sup>	316 SS
Spring button	Zinc-plated steel
Spring stabilizer <sup>②</sup>	301 SS
Range spring	316 SS or zinc-plated steel, depending on configuration
Nonwetted lubricant	Hydrocarbon-based
<i>Body, seat retainer, steam tube</i>	316 SS
<i>Seat</i>	PEEK
<i>Diaphragm,<sup>③</sup> poppet spring</i>	Alloy X-750
<i>Poppet</i>	S17400 SS
<i>Wetted lubricant</i>	PTFE-based

Wetted components listed in *italics*.

① Not shown.

② Not required in all configurations.

③ Regulators with control ranges higher than 0 to 100 psig (0 to 6.8 bar) are assembled with two diaphragms.

### Dimensions

Dimensions, in inches (millimeters), are for reference only and are subject to change.

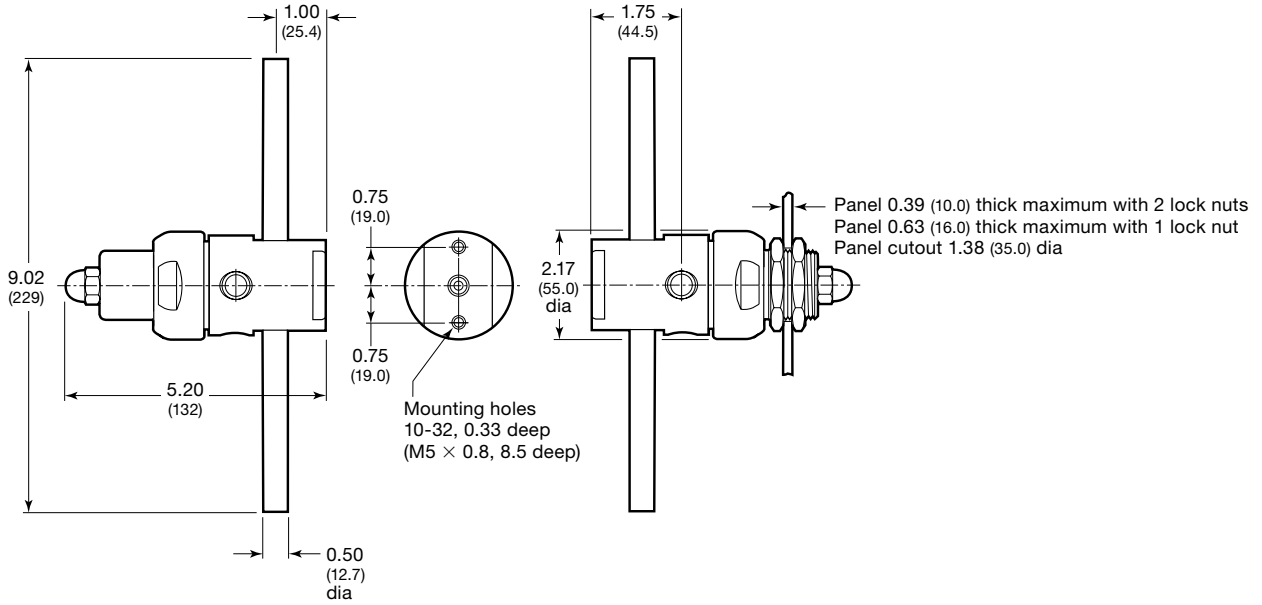

### Ordering Information

Build a KSV series regulator ordering number by combining the designators in the sequence shown below.



**4 Body Material**

- 1 = 316 SS
- A = 316 SS, ASTM G93 Level E-cleaned

**5 Pressure Control Range**

- C = 0 to 10 psig (0 to 0.68 bar)
- D = 0 to 25 psig (0 to 1.7 bar)
- E = 0 to 50 psig (0 to 3.4 bar)
- F = 0 to 100 psig (0 to 6.8 bar)
- G = 0 to 250 psig (0 to 17.2 bar)
- J = 0 to 500 psig (0 to 34.4 bar)

**6 Maximum Inlet Pressure<sup>①</sup>**

- F = 100 psig (6.8 bar)
- J = 500 psig (34.4 bar)
- L = 1000 psig (68.9 bar)
- R = 3600 psig (248 bar)

<sup>①</sup> For better resolution and control, select a pressure that closely matches system pressure.

**7 Port Configuration**

1, 4

See *Port Configurations, right*.

**8 Ports**

- 3 = 1/8 in. female NPT inlet;
- 1/4 in. female NPT outlet(s)

**9 Seat Material**

- 2 = PEEK

**10 Flow Coefficient (C<sub>v</sub>)**

- 2 = 0.06
- 5 = 0.20

**11 Sensing Mechanism, Vent**

- A = Alloy X-750 diaphragm, no vent
- E = Alloy X-750 diaphragm, captured vent, no self vent

**12 Handle, Mounting**

- 3 = Antitamper nut
- 7 = Antitamper nut, panel mount

**13 Valves**

- 0 = No valves

**14 Cylinder Connections**

- 0 = No connections

**15 Gauges**

- 0 = No gauges

**16 Options**

- 0 = No options

### Port Configurations

Configuration	Designator	Configuration	Designator
	1		4